

Lexus GX-470/ Toyota 4Runner/ Toyota Prado Coil Spring Kit

Air Spring Removal



WARNING: The air suspension system is under pressure (up to 10 bar, or 150 lbf/in²). Do not allow dirt or grease to enter the system. Always wear standard protective hand, ear, and eye protection when servicing the air suspension system.

Removal

1. Raise the vehicle on a hoist or with the proper lifting equipment. Suspension must be at full rebound with no load.



WARNING: Always support the chassis on safety stands. Refer to your vehicle's Owner's Manual for correct lifting instructions.

2. Remove both rear tires.
3. Deflate both rear air springs, by disconnecting the air lines leading from the valve block assembly to the rear air springs.
4. Remove the locking clip from the top side of the rear air spring.
5. Disconnect the air line from the air springs.
6. Carefully remove air spring from the vehicle.
7. Seal off hose to prevent dirt or grease from entering system.
8. Remove both lower shock bolts. Allow axle to hang free unsupported. This will give you extra clearance for the coil spring.

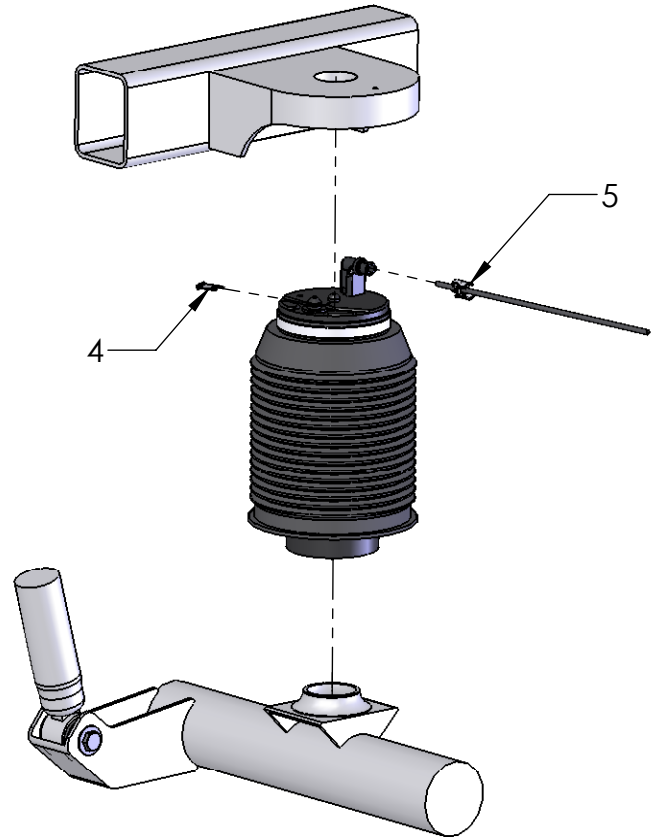

Coil Spring Installation

1. Install the upper spring isolator on top of the coil spring.
2. Install the rear springs onto the rear axle.
3. Using a floor jack, raise the rear axle.
4. Install the lower shock absorber retaining nut and bolt to the rear axle. Tighten the lower shock absorber retaining nut and bolt to 95 N-m (70 lb-ft).
5. Remove the rear axle support.
6. Replace tire and wheel assembly. Tighten wheel hub bolt nuts to 115-142 N-m (85-105 lb-ft).
7. Remove all safety stands and lower vehicle.



WARNING: Make sure to tighten all wheel hub bolt nuts to 115-142 Nm (85-105 lb-ft). Failure to heed to this warning could result in serious bodily and vehicular damage.

Disarming the Air Suspension System

Remove the fuse from the air suspension compressor. The 50 amp fuse is located in the fuse box under the hood. This will deactivate the air suspension system. The "off" light located next to the height control lamp will continue to blink. You will still be able to use the suspension dampening adjustment control to firm up the suspension shocks.

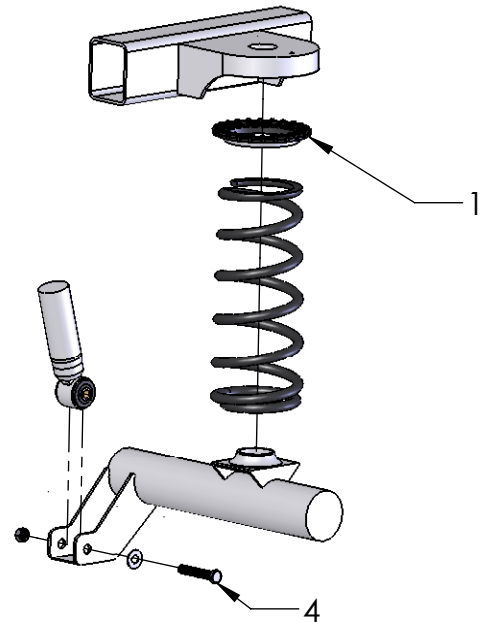

	DIMENSIONS ARE IN INCHES TOLERANCES: FRACTIONAL ± ANGULAR: MACH ± BEND ± TWO PLACE DECIMAL ± THREE PLACE DECIMAL ±		NAME KMD	DATE 04/21/10	C-2410 2003-2009 LEXUS GX 470 REAR COIL CONVERSION
	MATERIAL C-2410	FINISH	DRAWN CHECKED ENG APPR. MFG APPR. Q.A. COMMENTS:	SCALE: 1:8	
PROPRIETARY AND CONFIDENTIAL THE INFORMATION CONTAINED IN THIS DRAWING IS THE SOLE PROPERTY OF ARNOTT, INC. ANY REPRODUCTION IN PART OR AS A WHOLE WITHOUT THE WRITTEN PERMISSION OF ARNOTT, INC. IS PROHIBITED.	NEXT ASSY USED ON APPLICATION	DO NOT SCALE DRAWING	SCALE: 1:8	WEIGHT:	SHEET 1 OF 1